

■ HYDRAULIC INSPECTION ■

TEST PRESSURE MPa [kgf/cm ²]	BODY	4.12 [42.0]
	SEAT	3.02 [30.8]

■ PRESSURE RATING ■

FLUID CONDITION	MAXIMUM WORKING PRESSURE MPa [kgf/cm ²]
STEAM OF 205°C OR LESS	1.57 [16]
AIR, GAS, OIL AND PULSATION WATER	1.96 [20]
NON-SHOCK WATER OF 120°C OR LESS	2.75 [28]

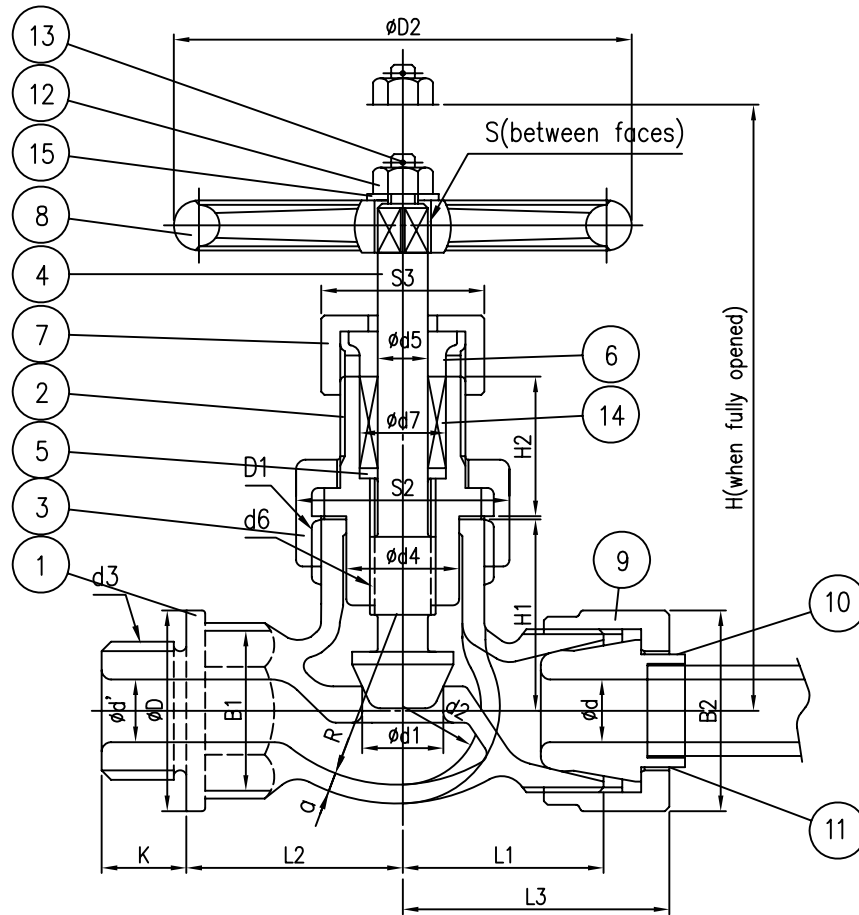

15	NAME PLATE	C2801P	1
14	PACKING	TEFLON	1set
13	SPLIT PIN	C2600W	1
12	HEXAGON NUT	C3771BD	1
11	NIPPLE FOR STEEL PIPE	S15C	1
10	NIPPLE FOR COPPER PIPE	C1100BD	1
9	UNION NUT	C3771BD	1
8	HANDWHEEL	FC200	1
7	GLAND NUT	C3771BD	1
6	PACKING GLAND	C3771BD	1
5	SEAT RING	C3771BD	1
4	STEM	C3771BD	1
3	BONNET NUT	C3771BD	1
2	BONNET	BC6	1
1	BODY	BC6	1

NO.	NAME OF PART	MATERIAL	Q'TY	REMARK	
REV	DATE	DESCRIPTION OF REASON	DRAW'G	CHK'D	APP'D

(Unit:mm)

Nominal dia.	Pipe out. dia.		d	d'	d1	L1	L2	L3 (Approx.)	Threads d3	K	D	Ht. (fully opened) H	Lift I	Hand-wheel D2	Body					Height of bonnet H2	Stem			Stuffing box d7	Between faces				WEIGHT (kg)	
	Copper pipe	steel pipe													d4	a	R	H1	Threads D1		d5	Threads d6	S		B1	B2	S2	S3		
6	8/10	10.5	6	8	8	32	32	41	M20x1.5	12	28	100	5.5	63	19	3	22	30	M27x2	17	22	8.5	M12	7	14	22	30	36	27	0.81
10	15	17.3	10	10	10	36	35	48	M24x2	16	34	115	7.5	80	26	3	26	33	M30x2	19	29	9.5	M12	8	16	27	41	41	30	1.22

DESCRIPTION	JIS F7388 CAST BRONZE 20kgf/cm ² GLOBE VALVE (S-TYPE)				
DRAW'G	CHK'D	APP'D	SCALE	NON	
H.J.YUN	S.M.BAB	S.M.BAB	UNIT	(mm) inch	
DATE	06.11.16	DWG NO.	KS-BC-GLS-4-A1	REV 0	



技星金屬株式會社
KEY SUNG METAL CO., LTD

■ HYDRAULIC INSPECTION ■

TEST PRESSURE MPa [kgf/cm ²]	BODY	4.12 [42.0]
	SEAT	3.02 [30.8]

■ PRESSURE RATING ■

FLUID CONDITION	MAXIMUM WORKING PRESSURE MPa [kgf/cm ²]
STEAM OF 205°C OR LESS	1.57 [16]
AIR, GAS, OIL AND PULSATION WATER	1.96 [20]
NON-SHOCK WATER OF 120°C OR LESS	2.75 [28]

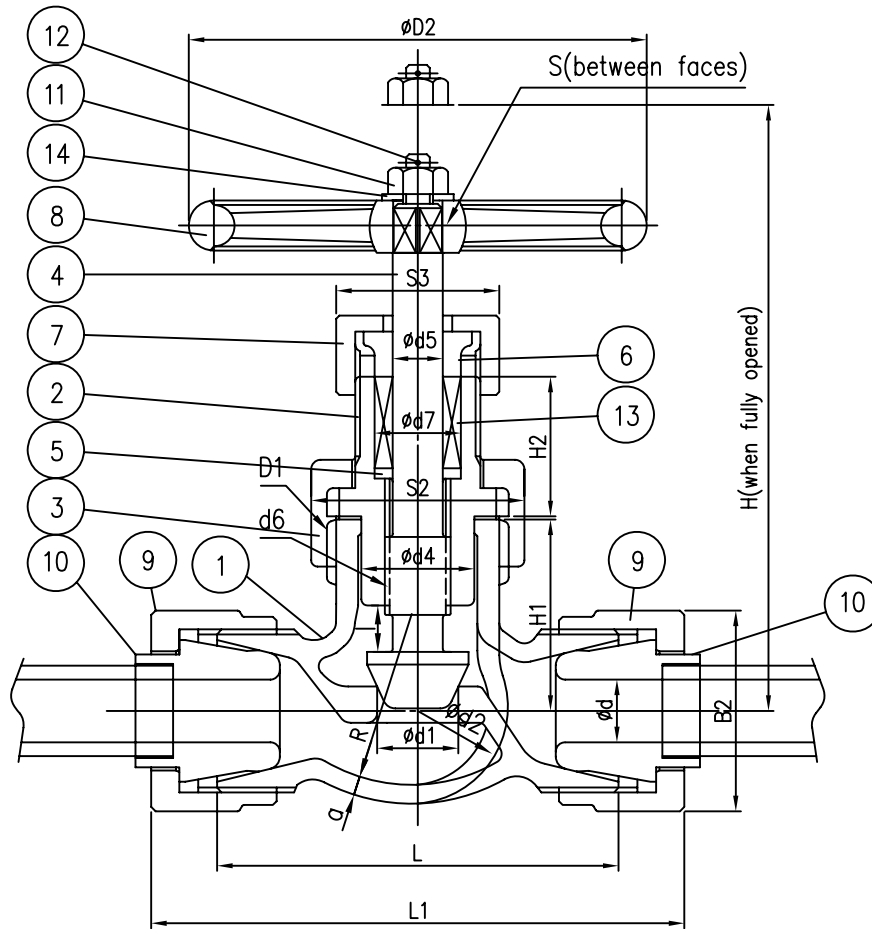

(Unit:mm)

Nominal dia.	Pipe out. dia.		d	d1	L	L1	Ht. (Approx.) H (fully opened)	Lift I	Hand-wheel D2	Body					Height of bonnet d4	Stem		Stuffing box d7	Between faces			WEIGHT (kg)		
	Copper pipe	steel pipe								d2	a	R	H1	Threads D1		d5	Threads d6		S	B2	S2		S3	
6	8/10	10.5	6	8	64	82	100	5.5	63	19	3	22	30	M27x2	17	22	8.5	M12	7	14	30	36	27	0.85
10	15	17.3	10	10	72	96	115	7.5	80	26	3	26	33	M30x2	19	29	9.5	M12	8	16	41	41	30	1.37

NO.	NAME OF PART	MATERIAL	Q'TY	REMARK
14	NAME PLATE	C2801P	1	
13	PACKING	TEFLON	1set	
12	SPLIT PIN	C2600W	1	
11	HEXAGON NUT	C3771BD	1	
10	NIPPLE FOR COPPER PIPE	C1100BD	1	
9	UNION NUT	C3771BD	1	
8	HANDWHEEL	FC200	1	
7	GLAND NUT	C3771BD	1	
6	PACKING GLAND	C3771BD	1	
5	SEAT RING	C3771BD	1	
4	STEM	C3771BD	1	
3	BONNET NUT	C3771BD	1	
2	BONNET	BC6	1	
1	BODY	BC6	1	

REV	DATE	DESCRIPTION OF REASON	DRAW'G	CHK'D	APP'D

DESCRIPTION	JIS F7388 CAST BRONZE 20kgf/cm ² GLOBE VALVE (U-TYPE)				
DRAW'G	CHK'D	APP'D	SCALE	NON	
H.J.YUN	S.M.BAE	S.M.BAE	UNIT	(mm) inch	
DATE	06.11.16	DWG NO.	KS-BC-GLU-4-A1	REV 0	

 技星金屬株式會社
 KEY SUNG METAL CO., LTD.