

TWO WAY COCK

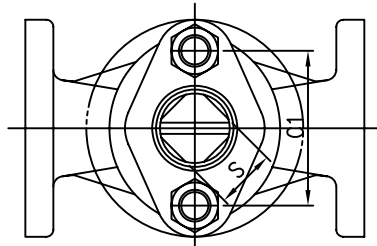

THREE WAY COCK

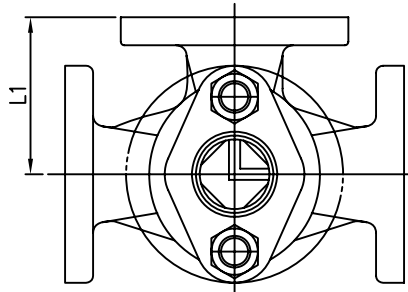

GROOVE INDICATING THE DIRECTION OF PORT

TYPE L

TYPE T

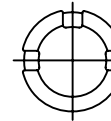
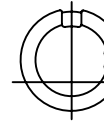
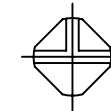

HYDRAULIC INSPECTION

TEST PRESSURE MPa(kgf/cm ²)	BODY	0.74 (7.5)
	PLUG	0.54 (5.5)

PRESSURE RATING

FLUID CONDITION	MAXIMUM WORKING PRESSURE MPa (kgf/cm ²)
WATER AND OIL	0.49 (5)

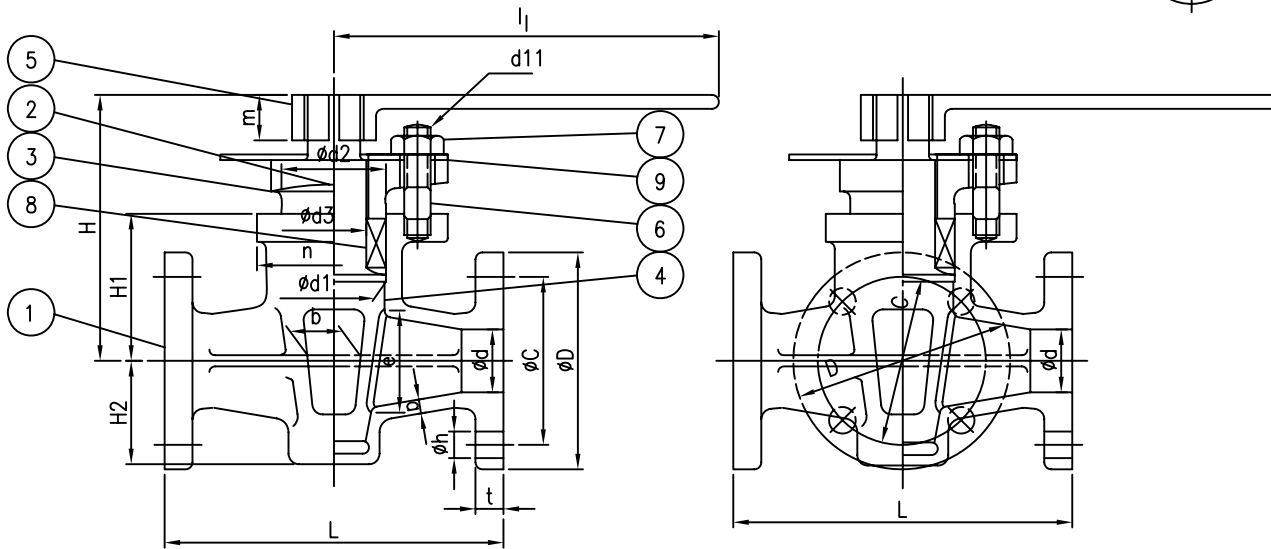

Bolt holes of flanges shall straddle body center lines.

(Unit:mm)

Nominal dia	Flange																			Normi. dia of Bolt	WEIGHT						
	d	L	L1	D	Bolt holes			Normi. dia of bolt	t	H	l	H1	H2	n	C1	e	b	d1	d2		d3	a	m	S	d11	(kg)	
					P.C. dia	n	h																			TWO WAY COCK	THREE WAY COCK
25	25	130	65	95	75	4	12	M10	10	105	160	58	41	60	65	40	16	41	43	28	5	18	17	M10	3.13	3.81	
32	32	160	80	115	90	4	15	M12	12	125	180	70	48	70	76	48	19	48	50	32	5	23	22	M12	5.02	6.13	
40	40	170	85	120	95	4	15	M12	12	135	190	78	57	82	88	58	23	58	60	42	6	25	24	M12	6.66	7.93	
50	50	190	95	130	105	4	15	M12	14	163	200	97	70	96	106	76	28	70	72	50	6	28	27	M16	10.0	11.8	
65	65	220	110	155	130	4	15	M12	14	201	250	123	86	125	132	96	38	94	96	70	7	37	36	M16	16.7	19.0	

9	NAME PLATE	C2801P	1	
8	PACKING	NON ASBESTOS	1	
7	HEXAGON NUT	C3771BD	2	
6	STUD	C3771BD	2	
5	HANDLE	S25C	1	
4	SEAT RING	BC6	1	
3	PACKING GLAND	BC6	1	
2	PLUG	BC6	1	
1	BODY	BC6	1	

NO.	NAME OF PART	MATERIAL	Q'TY	REMARK	
REV	DATE	DESCRIPTION OF REASON	DRAW'G	CHK'D	APP'D

DESCRIPTION	JIS F7381 CAST BRONZE 5kgf/cm ² FLANGE COCK (2-WAY, 3-WAY)				
DRAW'G	CHK'D	APP'D	SCALE	NON	
H.J.YUN	S.M.BAE	S.M.BAE	UNIT	(mm) inch	
DATE	06.11.16	DWG NO.	KS-BC-CO-1-A1	REV 0	

技星金屬株式會社
KEY SUNG METAL CO., LTD.