

■ HYDRAULIC INSPECTION ■

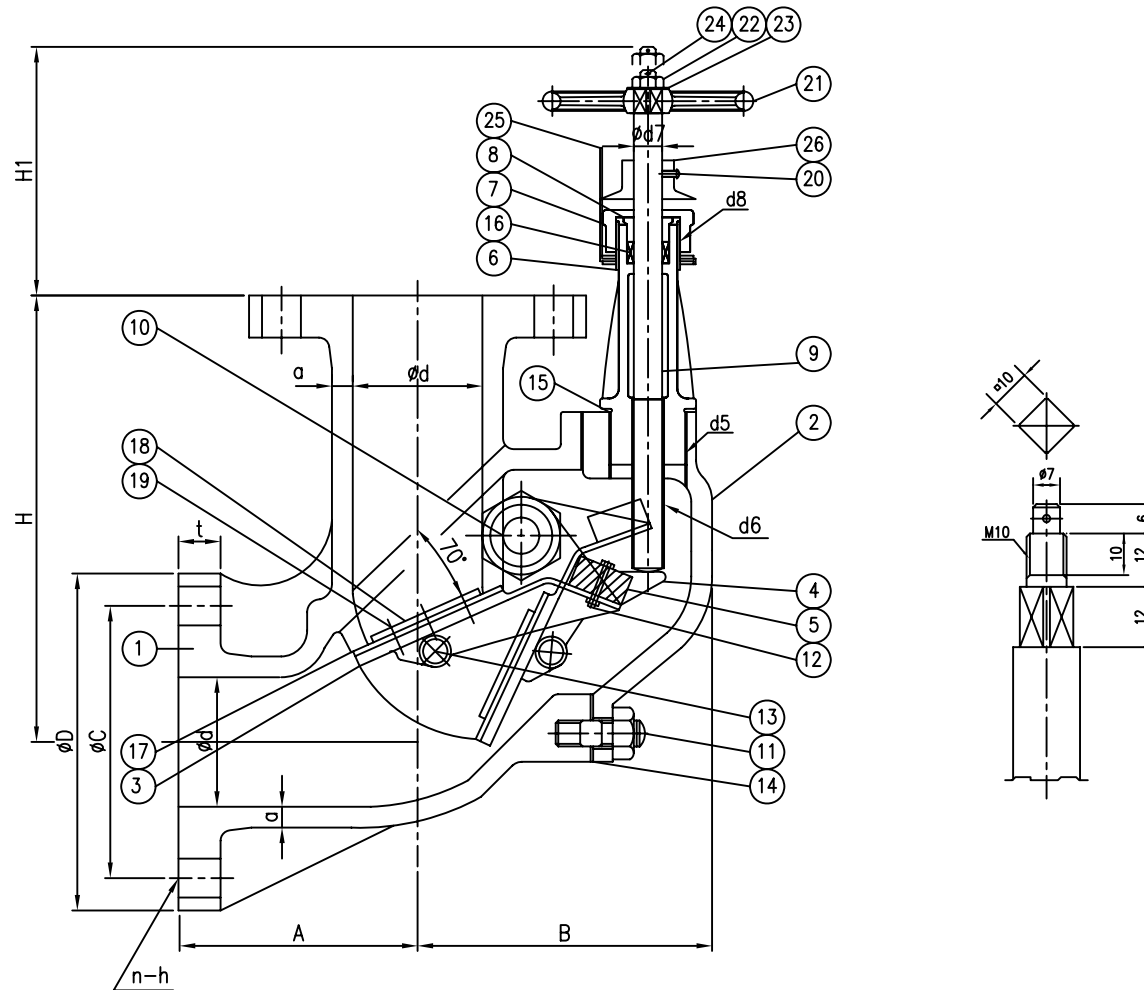

(Unit:mm)

Nominal dia.	F L A N G E											Threads			
	d	D	BOLT HOLE				A	B	a	H	H1	d7	d5	d6	d8
			P.C dia. C	No	h	t									
50	50	130	105	4	15	14	90	135	8	170	187	15	M38x2	TW20	M36x2
65	65	155	130	4	15	14	110	145	8	200	175	15	M38x2	TW20	M36x2
80	80	180	145	4	19	14	120	155	9	220	180	15	M38x2	TW20	M36x2
100	100	200	165	8	19	16	130	175	10	250	175	15	M38x2	TW20	M36x2
125	125	235	200	8	19	16	150	195	11	270	192	15	M38x2	TW20	M36x2
150	150	265	230	8	19	18	165	215	12	310	187	15	M38x2	TW20	M36x2
200	200	320	280	8	23	20	190	255	13	400	280	15	M38x2	TW20	M36x2

TEST PRESSURE MPa (kgf/cm ²)	BODY	0.5 [5.1]
	SEAT	0.2 [2]

26	INDICATOR	C3771BD	1	
25	INDICATOR PLATE	C2600P	1	
24	SPLIT PIN	C2600W	1	
23	NAME PLATE	C2801P	1	
22	HEXAGON NUT	C3604BD	1	
21	HANDLE	FC200	1	
20	SET SCREW	C3604BD	1	
19	SET SCREW FOR GASKET	SUS304	1	
18	SET PLATE FOR GASKET	C2600P	1	
17	GASKET	NBR	1	
16	PACKING	TEFLON	1set	
15	GASKET	NON-ASBESTOS	1	
14	GASKET	NON-ASBESTOS	1	
13	HEXAGON BOLT & NUT	SUS304	1set	
12	HEXAGON BOLT & NUT	SUS304	1set	
11	STUD BOLT & HEXAGON NUT	C3771BD	1set	
10	VALVE AXLE	SUS304	2	
9	SPINDLE	C3771BD	1	
8	PACKING GLAND	C3771BD	1	
7	PACKING GLAND NUT	C3604BD	1	
6	SPINDLE BOX	BC6	1	
5	COUNTER WEIGHT	Pb	1	
4	CLOSING ARM VALVE PLATE	BC6	1	
3	VALVE PLATE	BC6	1	
2	COVER	BC6	1	
1	BODY	BC6	1	

NO.	NAME OF PART	MATERIAL	Q'TY	REMARK
-----	--------------	----------	------	--------

REV	DATE	DESCRIPTION OF REASON	DRAW'G	CHK'D	APP'D
-----	------	-----------------------	--------	-------	-------

DESCRIPTION JIS F3060 CAST STEEL 5kgf/cm² SCREW DOWN ANGLE STORM VALVES

DRAW'G	CHK'D	APP'D	SCALE	NON
<i>H.J.YUN</i>	<i>S.M.BAB</i>	<i>S.M.BAB</i>	UNIT	(mm) inch
PROJECT				

DATE	06.11.16	DWG NO.	KS-SC-AGSTW-1-A1	REV	0
------	----------	---------	------------------	-----	---

技星金屬株式會社
KEY SUNG METAL CO., LTD.

■ HYDRAULIC INSPECTION ■

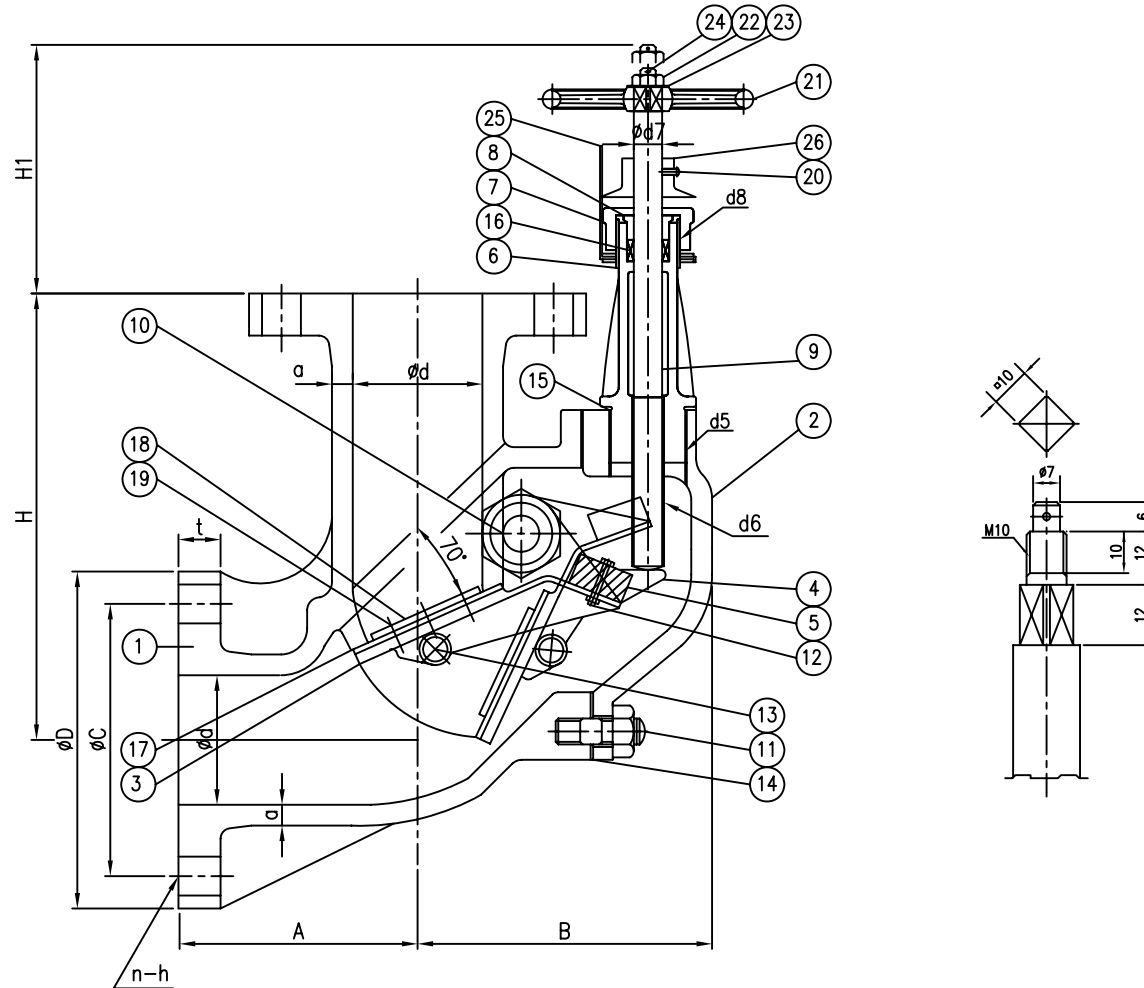

(Unit:mm)

Nominal dia.	F L A N G E											Threads			
	d	D	BOLT HOLE			t	A	B	a	H	H1	d7	d5	d6	d8
			P.C dia. C	No	h										
50	50	155	120	4	19	16	90	135	8	170	187	15	M38x2	TW20	M36x2
65	65	175	140	4	19	18	110	145	8	200	175	15	M38x2	TW20	M36x2
80	80	185	150	8	19	18	120	155	9	220	180	15	M38x2	TW20	M36x2
100	100	210	175	8	19	18	130	175	10	250	175	15	M38x2	TW20	M36x2
125	125	250	210	8	23	20	150	195	11	270	192	15	M38x2	TW20	M36x2
150	150	280	240	8	23	22	165	215	12	310	187	15	M38x2	TW20	M36x2
200	200	330	290	12	23	22	190	255	13	400	280	15	M38x2	TW20	M36x2

TEST PRESSURE MPa (kgf/cm ²)	BODY	0.5 [5.1]
	SEAT	0.2 [2]

26	INDICATOR	C3771BD	1	
25	INDICATOR PLATE	C2600P	1	
24	SPLIT PIN	C2600W	1	
23	NAME PLATE	C2801P	1	
22	HEXAGON NUT	C3604BD	1	
21	HANDLE	FC200	1	
20	SET SCREW	C3604BD	1	
19	SET SCREW FOR GASKET	SUS304	1	
18	SET PLATE FOR GASKET	C2600P	1	
17	GASKET	NBR	1	
16	PACKING	TEFLON	1set	
15	GASKET	NON-ASBESTOS	1	
14	GASKET	NON-ASBESTOS	1	
13	HEXAGON BOLT & NUT	SUS304	1set	
12	HEXAGON BOLT & NUT	SUS304	1set	
11	STUD BOLT & HEXAGON NUT	C3771BD	1set	
10	VALVE AXLE	SUS304	2	
9	SPINDLE	C3771BD	1	
8	PACKING GLAND	C3771BD	1	
7	PACKING GLAND NUT	C3604BD	1	
6	SPINDLE BOX	BC6	1	
5	COUNTER WEIGHT	Pb	1	
4	CLOSING ARM VALVE PLATE	BC6	1	
3	VALVE PLATE	BC6	1	
2	COVER	BC6	1	
1	BODY	BC6	1	

NO.	NAME OF PART	MATERIAL	Q'TY	REMARK
-----	--------------	----------	------	--------

REV	DATE	DESCRIPTION OF REASON	DRAW'G	CHK'D	APP'D
-----	------	-----------------------	--------	-------	-------

DESCRIPTION JIS F3060 CAST STEEL 10kgf/cm² SCREW DOWN ANGLE STORM VALVES

DRAW'G	CHK'D	APP'D	SCALE	NON
<i>H.J.YUN</i>	<i>S.M.BAB</i>	<i>S.M.BAB</i>	UNIT	(mm) inch
PROJECT				

DATE	06.11.16	DWG NO.	KS-SC-AGSTW-2-A1	REV	0
------	----------	---------	------------------	-----	---

技星金屬株式會社
KEY SUNG METAL CO., LTD.